



Containers & Warehouses

Main catalogue

Contents

CONTAINERS

Quick-Build-Containers	➤ Innovations 2023	4
	➤ Sustainability	5
	➤ Product advantages	6
	➤ Quick-Build-Container SC3000+	8
	➤ Quick-Build-Container SC3000+ Door systems	10
	➤ Storage Container SC10+ / SC20+ / SC40+	12
	➤ Quick-Build-Container SC3000+ Custom-Made	14
	➤ ThermoSafe TS+	16
	➤ Container Combination SCC2100+ / SCC2400+ coupled side-to-side	18
	➤ Container Combination SCC2100+ / SCC2400+ coupled end-to-end	20
	➤ Engineer's Shelter BPH+	22
	➤ Shelter US10+ / US20+	24
	➤ Mobile Box MB1+ / MB2+	26
	➤ Tool Security Box WSB+	28
➤ Gas Cylinder Container SGL+	30	

WAREHOUSES

Quick-Build-Warehouses	➤ Product advantages	32
	➤ At a glance	34
	➤ Quick-Build-Warehouse SBH2600 / SBH3200	36

APPLICATIONS / ACCESSORIES

Fields of application	➤ Building Sites	38
	➤ Housing	39
	➤ Storage Space for industry, crafts and trade	39
	➤ Self Storage	40
	➤ References Containers and Warehouses	41
Accessories / Options	➤ Tidiness and security	44
	➤ Security and comfort	45



Quick-Build-Container SC3000+

- Numerous upgraded details for greater benefit
- Higher stability and operational safety due to raised floor frame edge
- Optimised door design
- Further increased weather resistance



Assembly video



ThermoSafe TS+

The insulated multi-functional container: Ideally suited as material storage for temperature-sensitive goods, as a building site container or for the self storage industry.

Sustainability

We take responsibility for the environment

Consistent customer orientation, reliability and punctuality as well as a high level of flexibility relating to our products, technical advice and information are the foundations of our company.

Our environmental policy is based on the social and territorial responsibility.

In the whole social sector, the management and the employees are committed to continually work on improving the existent regulations in all facets of environmental protection. The requirements of DIN EN ISO 14001 and the environmental laws and regulations are fulfilled.

Our aim is to protect the environment as a whole and to avoid pollution.

We see the focus of the environmental principles in:

- reduction of consumption/resources
- reduction of waste materials
- promotion of awareness-raising among employees

In the territorial field, the target is to reduce environmental pollution for example noise, or not to exceed the customary standards unless in exceptional cases.

Our containers and warehouses have a very long service life - with practically no wear and tear - and can be almost completely recycled.

“For us, sustainability and responsibility mean in practice a clear conscience and profitability through green action!”

Thomas Bockholt (Sales Manager)

“The good cooperation with customers, suppliers, authorities, employees and the public helps us to continually improve our environmental proficiency.”

Tim Helmers (Storage Technology Sales Manager)

We use an **“Integrative Management System”**, as only certified quality prevails. Permanent monitoring and continuous improvement processes are the cornerstones of the BOS quality.



Quality



Safety



Environment



Energy

Quick-Build-Containers

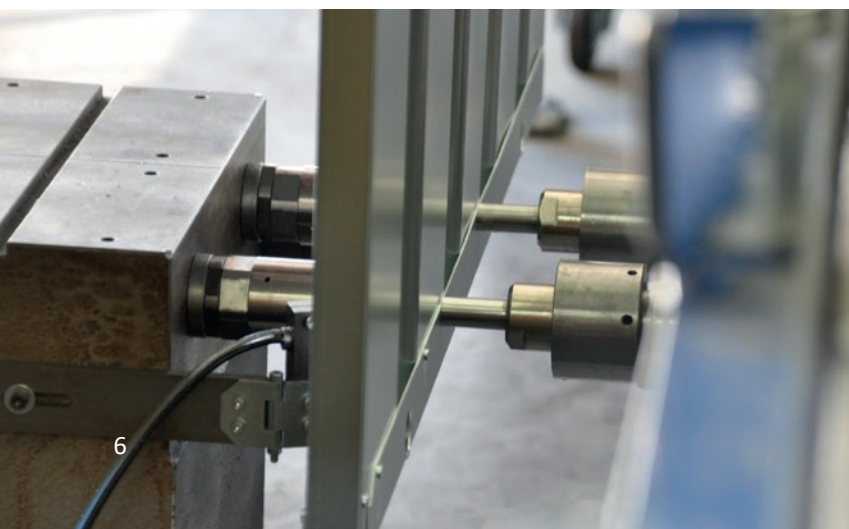



The proven standard for construction, industry and trade.

PRODUCT ADVANTAGES

- Sturdy, robust, durable and resistant
- Highest industrial safety, certified by TÜV and GS mark
- Protection from burglary and theft via profile cylinder lock and solid shoot bolt
- 4 jack rings and metal runners for easy on-site transportation
- Self assembly option (simple construction kit with detailed instructions)



THE CLASSIC
TAKEN FURTHER:
NO. 1 WORLDWIDE



PERFORMANCE REQUIREMENTS:

You are searching for a universally usable container for every application, on small building sites as well as for industry and crafts: flexible, mobile and yet sturdy and built in lightning speed.

With its detail optimisations, the SC3000+ ensures greater stability and operational reliability as well as further improved weather resistance.

Now new!
With raised floor
frame edge and further
improved weather
resistance

Quick-Build-Container SC3000+ (with and without flooring)

THE SOLUTION:

- 4 jack rings for easy on-site transportation, up to 3 tons can be lifted by crane (Exception: LZ version)
- Metal runners for forklift transport and for ground ventilation
- Snow load safety 210kg/m²
- Sturdy OSB wooden flooring
- Load bearing capacity 500kg/m² (permissible area load)
- Tool-free assembly, simple and quick – with 2 people in just 5 minutes (example 3x2m)

Delivery:

- Flat-packed
- Assembled

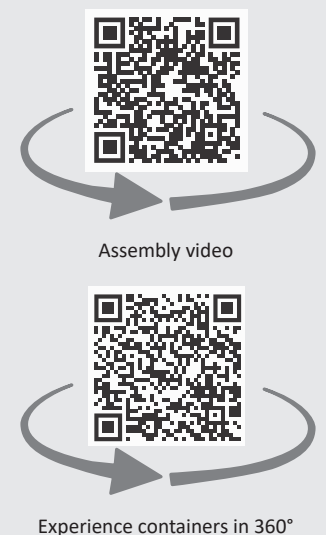



ATTENTION:

Optimised door sizes for SZ and LZ

Door arrangements:

(Details see page 10-11)

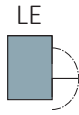

In side wall, single door: 1150x1890mm



In front face, single door: 1150x1890mm

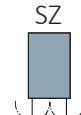

In front face, double door: **1750**x1890 mm

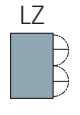

In side wall, double door: **1750**x1890 mm (without TÜV/GS) (not in stock)

SC3000+		1x2	2x2	3x2	4x2	5x2	6x2
Width external/internal (mm)		2100 / 1975	2100 / 1975	2100 / 1975	2100 / 1975	2100 / 1975	2100 / 1975
Depth external/internal (mm)		1100 / 975	2100 / 1975	3100 / 2975	4100 / 3975	5100 / 4975	6100 / 5975
Height external/internal (mm)		2100 / 1935	2100 / 1935	2100 / 1935	2100 / 1935	2100 / 1935	2100 / 1935
Weight (kg)		220	325	410	515	600	705

Bestseller

✓ All containers are also available without flooring for level access.

✓ All containers can also be supplied in a height of 2400mm (see SC3000+ Custom-Made page 14).



SC3000+2x2-SE



SC3000+2x2-SZ



SC3000+3x2-SE



SC3000+3x2-SZ

TOOL-FREE ASSEMBLY
simple and quick

ASSEMBLY / DISASSEMBLY
in 5 minutes

ACCESSORIES/OPTIONS:
See page 44-45 for details.

- | | |
|--|---|
| <ul style="list-style-type: none"> 1 Shelving system 2 Tool rail 3 Clothes rail 4 Hose and cable suspension 5 Burglar protection 6 Anti-theft security bar 7 VdS approved security lock | <ul style="list-style-type: none"> 8 Anti-condensation coating 9 Protective corner covers 10 Exterior painting 11 Access ramp 12 Electrical package 13 Light panel in the roof 14 Sliding window |
|--|---|

FIELDS OF APPLICATION:
See page 38-40 for details.

- Building Sites
- Storage Space
- Self Storage
- Storage Management

**HIGH STABILITY
AND SAFETY**



BEST OF STEEL



Made in Germany

Quick-Build-Container SC3000+ Door systems

CHOICE OF DOOR SYSTEM:

There are different door systems available for the SC3000. The versions SZ and SE are mounted in the front face, the versions LE and LZ are integrated in the side wall. All four corners of the container can be equipped with BOS protective corner covers. These offer increased stability and security, especially for the tough 'everyday life' on construction sites.

Quick-Build-Container SC3000+

Door systems

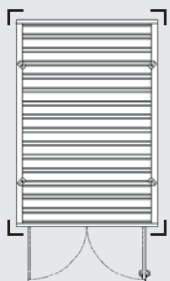

- SZ
- In front face
- Double door
- 1750 x 1890 mm
- Optional: 2 protective corner covers

ATTENTION:
Optimised door sizes

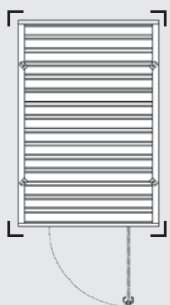

- SE
- In front face
- Single door
- 1150 x 1890 mm
- Optional: 4 protective corner covers

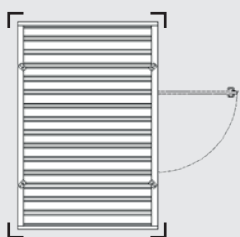

- LE
- In side wall
- Single door
- 1150 x 1890 mm
- Optional: 4 protective corner covers

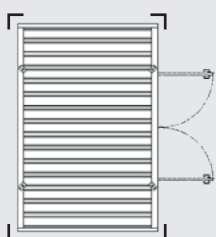

- LZ
- In side wall
- Double door
- 1750 x 1890 mm
- Optional: 4 protective corner covers

ATTENTION:
Optimised door sizes



THE BETTER
ALTERNATIVE TO A
SEA CONTAINER



PERFORMANCE REQUIREMENTS:

A large, inexpensive storage space is required for industry, crafts and trade as a better alternative to a sea container- robust and movable when necessary.

BEST OF STEEL

Made in Germany

Storage Container SC10+ / SC20+ / SC40+

THE SOLUTION:

- 4 jack rings for easy transportation, up to 3 tons can be lifted by crane (SC10+ / SC20+)
- Metal runners for forklift transport (SC10+ / SC20+) and for ground ventilation
- Snow load safety 210kg/m² (SC10+ / SC20+)
- Sturdy OSB wooden flooring
- Load bearing capacity 500kg/m² (permissible area load)
- Tool-free assembly, simple and quick – with 2 people in just 10 minutes (example SC10+)
- Protective corner covers for additional stability

Delivery:

- Flat-packed
- Assembled (SC10+ and SC20+)



Assembly video



(SC10+ / SC20+)

Door arrangements:

SE



In front face, single door: 1150x2235 mm

SZ



In front face, double door: 1950x2235 mm

ATTENTION:

Optimised door sizes for SZ

SC		10+	20+	40+ (= 2xSC20+, joined)
Width external/internal	(mm)	2300 / 2175	2300 / 2175	2300 / 2175
Depth external/internal	(mm)	3100 / 2975	6100 / 5975	12200 / 12075
Height external/internal	(mm)	2445 / 2280	2445 / 2280	2445 / 2280
Height lower edge of roof in coupling section	(mm)	–	–	2220
Weight	(kg)	475	810	1505



Version SC10+SE



Version SC10+SZ



TOOL-FREE ASSEMBLY simple and quick



ASSEMBLY / DISASSEMBLY in 10 minutes

ACCESSORIES/OPTIONS:
See page 44-45 for details.

- | | |
|-------------------------------------|------------------------------------|
| 1 Shelving system | 8 Anti-condensation coating |
| 2 Tool rail | 10 Exterior painting |
| 3 Clothes rail | 11 Access ramp |
| 4 Hose and cable suspension | 12 Electrical package |
| 5 Burglar protection | 13 Light panel in the roof |
| 6 Anti-theft security bar | 14 Sliding window |
| 7 VdS approved security lock | |

FIELDS OF APPLICATION:
See page 38-40 for details.

- Building Sites
- Storage Space
- Self Storage
- Storage Management
- Tyre Storage

CUSTOM-MADE



Illustration
with optional paint finish

BEST OF STEEL



Made in Germany

PERFORMANCE REQUIREMENTS:

You need an **individual container** for your **specific needs**, for example with particular dimensions or equipment requirements for special purposes.

Length, width and height- all according to your wishes!





Quick-Build-Container SC3000+ Custom-Made (with and without flooring)

THE SOLUTION:

- Non-standard sizes are available in steps of +/-200mm in depth and width
- Special heights and customised accessories can also be supplied
- The door arrangement is individually possible in the front and side walls



Assembly video

	Door arrangements:	 In front face, single door, variable	 In front face, double door, variable	 In side wall, single door, variable	 In side wall, double door, variable
SC3000+ Custom-Made					
Width	(mm)	700 to 2900			
Depth	(mm)	700 to 6100			
Height	(mm)	1600 / 2100 / 2400 / 2600			

 **All containers are also available without flooring for level access.**



Balcony containers provide extra space where housing is confined



Slim design container



Can be lifted by crane on building sites









Custom-made container with ventilation apertures

ACCESSORIES/OPTIONS:
See page 44-45 for details.

- | | |
|-------------------------------------|------------------------------------|
| 1 Shelving system | 8 Anti-condensation coating |
| 2 Tool rail | 9 Protective corner covers |
| 3 Clothes rail | 10 Exterior painting |
| 4 Hose and cable suspension | 11 Access ramp |
| 5 Burglar protection | 12 Electrical package |
| 6 Anti-theft security bar | 13 Light panel in the roof |
| 7 VdS approved security lock | 14 Sliding window |

FIELDS OF APPLICATION:
See page 38-40 for details.

- | | |
|---|--------------------|
|  | Building Sites |
|  | Housing |
|  | Storage Space |
|  | Self Storage |
|  | Storage Management |
|  | Tyre Storage |

NEW + INSULATED



PERFORMANCE REQUIREMENTS:

What is needed is a **multifunctional storage container** for temperature-sensitive goods, for drinks and interim storage, for the storage of household goods and furniture, for storing documents/archiving, as a classic building site container or for the self storage industry.

ThermoSafe TS+

THE SOLUTION:

- 40mm PUR sandwich panels in walls and roof, encased in galvanized and painted covering shells
- Fully galvanized, welded and painted steel frame construction
- High quality wooden floor with PVC flooring
- Load capacity 200kg/m² (permissible area load)
- Insulated aluminium door with high quality seal
- Snow load safety 125kg/m²
- High anti-theft protection via mortise lock and profile cylinder
- Integrated jack rings for easy transportation (can be lifted by crane when empty)
- Forklift pockets for transport

Delivery:

- Assembled

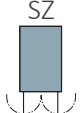
		Door arrangements:  		
		In front face, single door: 1050x2200 mm		In front face, double door: 1800x2200 mm
TS+		3x2	4x2	6x2
Width external/internal	(mm)	2420 / 2250	2420 / 2250	2420 / 2250
Depth external/internal	(mm)	3090 / 2920	4090 / 3920	6090 / 5920
Height external/internal	(mm)	2480 / 2200	2480 / 2200	2480 / 2200
Weight	(kg)	690	810	1080



Wall convector







Sliding window 760x1020mm with grille







Electrical package (10W LED light with switch, 16A Schuko plug, fuse box, outdoor connection and earth cable)

ACCESSORIES/OPTIONS:

-  Wall convector
-  Sliding window
-  Electrical package
-  Insulated floor
-  Double leaf door 1800x2200mm

FIELDS OF APPLICATION:

See page 38-40 for details.

-  Building Sites
-  Storage Space
-  Self Storage
-  Storage Management

SPACE MIRACLE
Up to 30m²



BEST OF STEEL



Made in Germany

PERFORMANCE REQUIREMENTS:

Your space requirement is up to 30m², making it too much for a normal container. At the same time you want a low-cost and **movable** at anytime storage concept with a high cost-benefit ratio. You can also use the ContainerCombination as a mini warehouse.





ContainerCombination coupled side-to-side SCC2100+ / SCC2400+ (with and without flooring)





THE SOLUTION:

- Stable and rigid construction, based on the Quick-Build-Container SC3000+
- Metal runners for ground ventilation
- Sturdy OSB wooden flooring
- Load bearing capacity 500kg/m² (permissible area load)
- The assembly is as for the Quick-Build-Container – simple and fast
- Protective corner covers for additional stability

Delivery:

- Flat-packed

 <p>2100 mm height</p> <p>SCC2100+</p> <p>ATTENTION: Optimised door sizes for LZ</p>	<p>Door arrangements:</p>     <p>In side wall, single: 1150x1890mm In side wall, single: 1150x1890mm In side wall, double: 1750x1890mm In side wall, double: 1750x1890mm</p>																																									
	<p>SCC2100+ side-to-side</p> <table border="1"> <thead> <tr> <th></th> <th>3x4</th> <th>3x6</th> <th>4x4</th> <th>4x6</th> <th>5x4</th> <th>5x6</th> </tr> </thead> <tbody> <tr> <td>Width external/internal (mm)</td> <td>4200 / 4075</td> <td>6300 / 6175</td> <td>4200 / 4075</td> <td>6300 / 6175</td> <td>4330 / 4205</td> <td>6560 / 6435</td> </tr> <tr> <td>Depth external/internal (mm)</td> <td>3100 / 2975</td> <td>3100 / 2975</td> <td>4100 / 3975</td> <td>4100 / 3975</td> <td>5100 / 4975</td> <td>5100 / 4975</td> </tr> <tr> <td>Height external/internal (mm)</td> <td>2100 / 1935</td> <td>2100 / 1935</td> <td>2100 / 1935</td> <td>2100 / 1935</td> <td>2315 / 1935</td> <td>2315 / 1935</td> </tr> <tr> <td>Height lower edge of roof in coupling section (mm)</td> <td>1775</td> <td>1775</td> <td>1705</td> <td>1705</td> <td>1875</td> <td>1875</td> </tr> <tr> <td>Weight (kg)</td> <td>725</td> <td>1025</td> <td>910</td> <td>1295</td> <td>1130</td> <td>1645</td> </tr> </tbody> </table>		3x4	3x6	4x4	4x6	5x4	5x6	Width external/internal (mm)	4200 / 4075	6300 / 6175	4200 / 4075	6300 / 6175	4330 / 4205	6560 / 6435	Depth external/internal (mm)	3100 / 2975	3100 / 2975	4100 / 3975	4100 / 3975	5100 / 4975	5100 / 4975	Height external/internal (mm)	2100 / 1935	2100 / 1935	2100 / 1935	2100 / 1935	2315 / 1935	2315 / 1935	Height lower edge of roof in coupling section (mm)	1775	1775	1705	1705	1875	1875	Weight (kg)	725	1025	910	1295	1130
	3x4	3x6	4x4	4x6	5x4	5x6																																				
Width external/internal (mm)	4200 / 4075	6300 / 6175	4200 / 4075	6300 / 6175	4330 / 4205	6560 / 6435																																				
Depth external/internal (mm)	3100 / 2975	3100 / 2975	4100 / 3975	4100 / 3975	5100 / 4975	5100 / 4975																																				
Height external/internal (mm)	2100 / 1935	2100 / 1935	2100 / 1935	2100 / 1935	2315 / 1935	2315 / 1935																																				
Height lower edge of roof in coupling section (mm)	1775	1775	1705	1705	1875	1875																																				
Weight (kg)	725	1025	910	1295	1130	1645																																				





 <p>2400 mm height</p> <p>SCC2400+</p> <p>ATTENTION: Optimised door sizes for LZ</p>	<p>Door arrangements:</p>     <p>In side wall, single: 1150x2235mm In side wall, single: 1150x2235mm In side wall, double: 1750x2235 mm In side wall, double: 1750x2235mm</p>																																									
	<p>SCC2400+ side-to-side</p> <table border="1"> <thead> <tr> <th></th> <th>3x4</th> <th>3x6</th> <th>4x4</th> <th>4x6</th> <th>5x4</th> <th>5x6</th> </tr> </thead> <tbody> <tr> <td>Width external/internal (mm)</td> <td>4200 / 4075</td> <td>6300 / 6175</td> <td>4200 / 4075</td> <td>6300 / 6175</td> <td>4330 / 4205</td> <td>6560 / 6435</td> </tr> <tr> <td>Depth external/internal (mm)</td> <td>3100 / 2975</td> <td>3100 / 2975</td> <td>4100 / 3975</td> <td>4100 / 3975</td> <td>5100 / 4975</td> <td>5100 / 4975</td> </tr> <tr> <td>Height external/internal (mm)</td> <td>2445 / 2280</td> <td>2445 / 2280</td> <td>2445 / 2280</td> <td>2445 / 2280</td> <td>2660 / 2280</td> <td>2660 / 2280</td> </tr> <tr> <td>Height lower edge of roof in coupling section (mm)</td> <td>2120</td> <td>2120</td> <td>2050</td> <td>2050</td> <td>2220</td> <td>2220</td> </tr> <tr> <td>Weight (kg)</td> <td>770</td> <td>1085</td> <td>960</td> <td>1360</td> <td>1190</td> <td>1715</td> </tr> </tbody> </table>		3x4	3x6	4x4	4x6	5x4	5x6	Width external/internal (mm)	4200 / 4075	6300 / 6175	4200 / 4075	6300 / 6175	4330 / 4205	6560 / 6435	Depth external/internal (mm)	3100 / 2975	3100 / 2975	4100 / 3975	4100 / 3975	5100 / 4975	5100 / 4975	Height external/internal (mm)	2445 / 2280	2445 / 2280	2445 / 2280	2445 / 2280	2660 / 2280	2660 / 2280	Height lower edge of roof in coupling section (mm)	2120	2120	2050	2050	2220	2220	Weight (kg)	770	1085	960	1360	1190
	3x4	3x6	4x4	4x6	5x4	5x6																																				
Width external/internal (mm)	4200 / 4075	6300 / 6175	4200 / 4075	6300 / 6175	4330 / 4205	6560 / 6435																																				
Depth external/internal (mm)	3100 / 2975	3100 / 2975	4100 / 3975	4100 / 3975	5100 / 4975	5100 / 4975																																				
Height external/internal (mm)	2445 / 2280	2445 / 2280	2445 / 2280	2445 / 2280	2660 / 2280	2660 / 2280																																				
Height lower edge of roof in coupling section (mm)	2120	2120	2050	2050	2220	2220																																				
Weight (kg)	770	1085	960	1360	1190	1715																																				

 **All containers are also available without flooring for level access.**

ACCESSORIES/OPTIONS:
See page 44-45 for details.

- | | |
|-------------------------------------|------------------------------------|
| 1 Shelving system | 8 Anti-condensation coating |
| 2 Tool rail | 10 Exterior painting |
| 3 Clothes rail | 11 Access ramp |
| 4 Hose and cable suspension | 12 Electrical package |
| 5 Burglar protection | 13 Light panel in the roof |
| 6 Anti-theft security bar | 14 Sliding window |
| 7 VdS approved security lock | |

FIELDS OF APPLICATION:
See page 38-40 for details.

- | | |
|---|--------------------|
|  | Building Sites |
|  | Storage Space |
|  | Self Storage |
|  | Storage Management |



PERFORMANCE REQUIREMENTS:

You have to store long objects (e.g. pipes) and are searching for an easily relocatable solution with a depth of up to 12m. At the same time you want a cost-effective and safe storage location with a high benefit/cost ratio. You can also use the ContainerCombination as a mini warehouse.

ContainerCombination coupled end-to-end SCC2100+ / SCC2400+ (with and without flooring)

THE SOLUTION:

- Stable and rigid construction, based on the Quick-Build-Container SC3000+
- Metal runners for ground ventilation
- Sturdy OSB wooden flooring
- Load bearing capacity 500kg/m² (permissible area load)
- The assembly is as for the Quick-Build-Container – simple and fast
- Protective corner covers for additional stability

Delivery:

- Flat-packed

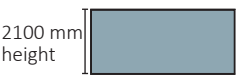
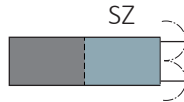
<p>Measurements in mm</p>  <p>2100 mm height</p> <p>SCC2100+</p>	<p>Door arrangements:</p>  <p>In side wall, double: 1750x1890 mm</p> <p>ATTENTION: Optimised door sizes for SZ</p>						
SCC2100+ end-to-end	6x2	7x2	8x2	9x2	10x2	11x2	12x2
Width external/internal	2100/1975	2100/1975	2100/1975	2100/1975	2100/1975	2100/1975	2100/1975
Depth external/internal	6200/6075	7200/7075	8200/8075	9200/9075	10200/10075	11200/11075	12200/12075
Height external/internal	2100/1935	2100/1935	2100/1935	2100/1935	2100/1935	2100/1935	2100/1935
Height lower edge of roof in coupling section	1875	1875	1875	1875	1875	1875	1875
Weight (kg)	750	855	965	1050	1135	1245	1350

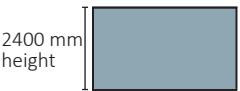
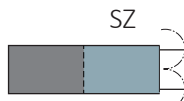



<p>Measurements in mm</p>  <p>2400 mm height</p> <p>SCC2400+</p>	<p>Door arrangements:</p>  <p>In side wall, double: 1750x2235 mm</p> <p>ATTENTION: Optimised door sizes for SZ</p>						
SCC2400+ end-to-end	6x2	7x2	8x2	9x2	10x2	11x2	12x2
Width external/internal	2100/1975	2100/1975	2100/1975	2100/1975	2100/1975	2100/1975	2100/1975
Depth external/internal	6200/6075	7200/7075	8200/8075	9200/9075	10200/10075	11200/11075	12200/12075
Height external/internal	2445/2280	2445/2280	2445/2280	2445/2280	2445/2280	2445/2280	2445/2280
Height lower edge of roof in coupling section	2220	2220	2220	2220	2220	2220	2220
Weight (kg)	810	920	1030	1125	1215	1325	1440

 **All containers are also available without flooring for level access.**

ACCESSORIES/OPTIONS:
See page 44-45 for details.

- | | |
|-------------------------------------|------------------------------------|
| 1 Shelving system | 8 Anti-condensation coating |
| 2 Tool rail | 10 Exterior painting |
| 3 Clothes rail | 11 Access ramp |
| 4 Hose and cable suspension | 12 Electrical package |
| 5 Burglar protection | 13 Light panel in the roof |
| 6 Anti-theft security bar | 14 Sliding window |
| 7 VdS approved security lock | |

FIELDS OF APPLICATION:
See page 38-40 for details.

- | | |
|---|--------------------|
|  | Building Sites |
|  | Storage Space |
|  | Self Storage |
|  | Storage Management |

BEST OF STEEL

 Made in Germany



PERFORMANCE REQUIREMENTS:

You are looking for a mini-office on the building site for architects and site managers which is a safe storage place for plans and drawings at the same time.

Engineer's Shelter BPH+

THE SOLUTION:

- A door catch prevents the door from slamming
- 4 jack rings for easy transportation
- Can be lifted by crane when empty
- Forklift pockets for transport
- Sturdy OSB wooden flooring
- Load bearing capacity 500kg/m² (permissible area load)
- Protective corner covers for additional stability

Delivery:

- Assembled

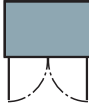
ATTENTION: Optimised door sizes	Door arrangements:	
	 <p>Roof overhang: 1x2 m, double door: 1750x1890 mm</p>	
Width external/internal (mm)	2100 / 1975	
Depth external/internal (mm)	1100 / 975 (2100mm incl. roof overhang)	
Height external/internal (mm)	2080 / 1935	
Weight (incl. accessories) (kg)	280	

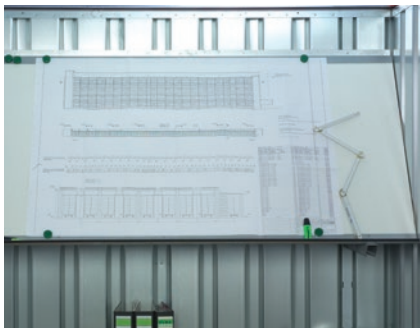

Drawing board with 1 shelf





Drawing shelf



Light panel in the roof

ACCESSORIES/OPTIONS:
See page 44-45 for details.

- 5** Burglar protection
 - 6** Anti-theft security bar
 - 7** VdS approved security lock
 - 8** Anti-condensation coating
 - 10** Exterior painting
 - 11** Access ramp
 - 12** Electrical package
-  Drawing board with 1 shelf
 -  Drawing shelf
 -  Light panel in the roof

FIELDS OF APPLICATION:
See page 38-40 for details.



Building Sites

BEST OF STEEL



Made in Germany



PERFORMANCE REQUIREMENTS:

What is wanted is a shelter that **protects against wind and weather** while being **freely accessible**. It should be practical and generously sized and suitable for the storage of materials, equipment, vehicles or as a shelter for people and animals.

Shelter US10+ / US20+

THE SOLUTION:

- Floor-level, threshold-free access
- Ground fastening with ground nails
- Ground fastening with dowels on foundation as option
- Assembly simple and fast without special tools
- Protective corner covers for additional stability

Delivery:

- Flat-packed

US	US10+	US20+
Width external/internal (mm)	2300 / 2175	2300 / 2175
Depth external/internal (mm)	3100 / 2975	6100 / 5975
Height external/internal (mm)	2380 / 2340	2380 / 2340
Entrance height (supports) (mm)	2140	2140
Weight (kg)	340	530



US20+ as a combi-shelter for waste containers and bicycles



US20+ for housing wire mesh crates – quicker access with fork-lift or pallet trucks







US20+ as a shelter for bicycles

ACCESSORIES/OPTIONS: See page 44-45 for details.

- | | |
|--------------------------|------------------------------------|
| 1 Shelving system | 4 Hose and cable suspension |
| 2 Tool rail | 8 Anti-condensation coating |
| 3 Clothes rail | 10 Exterior painting |

FIELDS OF APPLICATION: See page 38-40 for details.

-  Building Sites
-  Housing
-  Storage Space
-  Storage Management

BEST OF STEEL

 Made in Germany



PERFORMANCE REQUIREMENTS:

What is needed is a **lockable, mobile storage cupboard or tool trolley** which provides weather, material and theft protection – in particular on large building sites with several floors, but also in workshops and factories. For daily use it must be especially robust and secure.

Mobile Box MB1+ / MB2+

THE SOLUTION:

- 4 jack rings as standard. Can be lifted by crane: MB1+ up to 300kg, MB2+ up to 600kg
- Metal runners for safe forklift transport and for ground ventilation
- Protective corner covers for additional stability
- Snow load safety 210kg/m²
- Sturdy OSB wooden flooring
- Load bearing capacity 500kg/m² (permissible area load)

Delivery:

- Assembled



**ATTENTION:
Optimised door sizes**

Door arrangements:



Single door,
750x1390mm

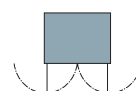

Double door,
1750x1390mm

MB	MB1+	MB2+
Width external/internal (mm)	1100 / 975	2100 / 1975
Depth external/internal (mm)	700 / 575	700 / 575
Height external/internal (mm)	1600 / 1435	1600 / 1435
Height with castors external/internal (mm)	1795 / 1435	1795 / 1435
Weight (kg)	100	160



Swivel and fixed castors:
load 300kg/castor



Version MB1+







Version MB2+

ACCESSORIES/OPTIONS:
See page 44-45 for details.

- | | |
|--------------------------------------|--|
| 1 Shelving system | 6 Anti-theft security bar |
| 2 Tool rail | 7 VdS approved security lock for MB2+ |
| 3 Clothes rail | 8 Anti-condensation coating |
| 4 Hose and cable suspension | 10 Exterior painting |
| 5 Burglar protection for MB2+ | ↗ Swivel and fixed castors |

FIELDS OF APPLICATION:
See page 38-40 for details.

-  Building Sites
-  Storage Space
-  Self Storage
-  Storage Management



BEST OF STEEL



Made in Germany

PERFORMANCE REQUIREMENTS:

For the **safe storage** of personal tools, small appliances and general equipment, a storage facility is needed which can be used on lorries, vans, trailers, flatbed vehicles or directly on the building site. A high level of theft, weather and material protection as well as simple loading are essential requirements.

Tool Security Box WSB+

THE SOLUTION:

- As a 'safe' for valuable tools and appliances
- Can be firmly attached to the vehicle
- Gas struts prevent slamming of the lid
- Transport of the box:
 - manual (4 handles)
 - forklift truck (forklift pockets, also for ventilation)
 - crane (4 jack rings), can be lifted by crane up to 250kg permissible total weight
- Protective corner covers for additional stability
- Sturdy OSB wooden flooring
- Load bearing capacity 500kg/m² (permissible area load)

Delivery:

- Assembled

WSB+		
Width external/internal	(mm)	1900 / 1770
Depth external/internal	(mm)	700 / 570
Height external/internal	(mm)	875 / 750
Weight	(kg)	105



2 optional discus locks



Typical on a building site:
a WSB+ on a utility vehicle

ACCESSORIES/OPTIONS:
See page 44-45 for details.

10 Exterior painting

↗ 2 discus locks

FIELDS OF APPLICATION:
See page 38-40 for details.



Building Sites



Storage Management



BEST OF STEEL

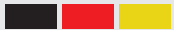

Made in Germany

PERFORMANCE REQUIREMENTS:

An economical and safe storage solution is required for the legally compliant storage of gas cylinders.





Gas Cylinder Container SGL+

THE SOLUTION:

- Holding brackets and straps protect the gas cylinders from falling over
- 4 jack rings for easy transportation
- Can be lifted by crane when empty
- Metal runners for safe forklift transport and for ground ventilation
- Grate floor for natural ventilation
- Load bearing capacity 500kg/m² (permissible area load)

Delivery:

- Assembled

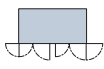
Door arrangements:	SE	SZ	SZ	LE/LE	LZ/LZ
ATTENTION: Optimised door sizes for SZ	 1x single door: 1305x1890mm	 1x double door: 1750x1890mm	 1x double door: 1750x1890mm	 2x single doors: 1305x1890mm	 2x double doors: 1750x1890mm
SGL+	1,5x1,5	1x2	2x2	3x2	4x2
Width external/internal (mm)	1500 / 1375	2100 / 1975	2100 / 1975	2100 / 1975	2100 / 1975
Depth external/internal (mm)	1500 / 1375	1100 / 975	2100 / 1975	3100 / 2975	4100 / 3975
Height external/internal (mm)	2100 / 1935	2100 / 1935	2100 / 1935	2100 / 1935	2100 / 1935
Storage capacity (Amount)					
• 5kg (Ø 230mm)	32	32	75	104	149
• 11kg (Ø 300mm)	18	18	42	58	90
• 33kg (Ø 320mm)	16	18	39	60	81
• 50kg (Ø 230mm)	32	32	75	104	149
Weight (incl. accessories) (kg)	240	240	350	500	650

 **All Gas Cylinder Containers are also available without flooring for level access.**



SGL+ 1,5x1,5 SE



SGL+ 1x2 SZ



SGL+ 3x2 LE/LE



SGL+ 4x2 LZ/LZ

ACCESSORIES/OPTIONS:
See page 44-45 for details.

- 6** Anti-theft security bar
- 10** Exterior painting
- 11** Access ramp

FIELDS OF APPLICATION:
See page 38-40 for details.



Storage Space

Quick-Build-Warehouses





The proven standard for construction, industry and trade.

PRODUCT ADVANTAGES

- Simple assembly in a very short time
- Demountable at any time for relocation
- Verifiable structural analysis according to Eurocode 3



ASSEMBLY IN JUST
A FEW HOURS
quick & easy



DIN EN 1090
REG.-NR. 0114502



Quick-Build-Warehouses

At a glance

The right warehouse for every area of application

SBH2600

Height 2.60m

➤ Width: 4 to 7m

➤ Depth: 4 to 30m

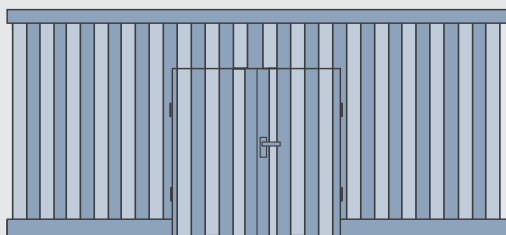

The roller shutter and door arrangements shown are examples only.

SBH3200

Height 3.20m

➤ Width: 4 to 7m

➤ Depth: 4 to 30m

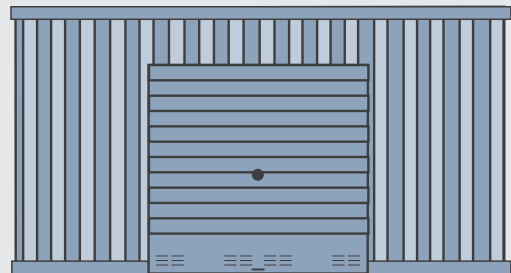

! Tip: The ContainerCombination SCC2100+/SCC2400+ is also suitable for use as a mini warehouse (Pages 18 to 21).

Assembly



Simply build it yourself ...

Save money by assembling your new warehouse yourself. We help by providing detailed and illustrated assembly instructions and exact, prefabricated parts.



... or have it built for you!

The Quick-Build-Warehouse SHB 3200 7x14m assembly needs four people and one day. If you don't have the time, our professional assembly team can do it quickly for you – at a fixed price!

Quick-Build-Warehouses

At a glance



Individual expansion

We would be happy to inform you whether your existing Quick-Build-Warehouse can be extended. Please contact us!

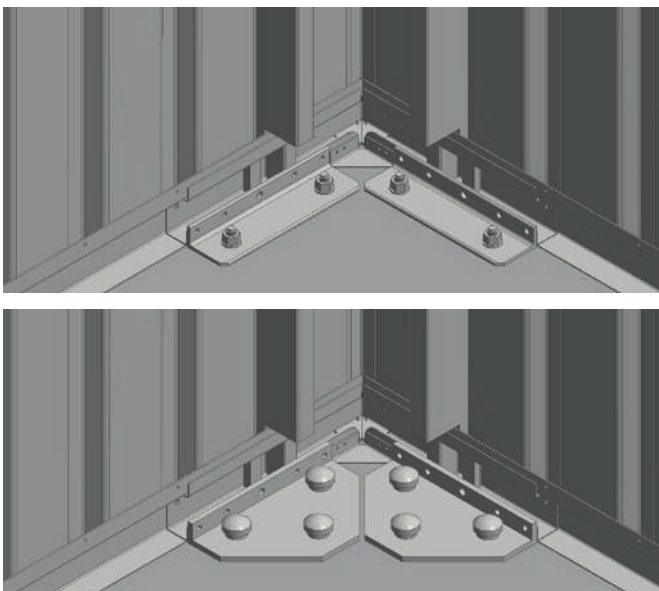

Ground anchorage with dowels (top) or ground nails (bottom)

- Ground anchorage with dowels on foundation
- Alternatively, cost-effective ground anchorage with ground nails

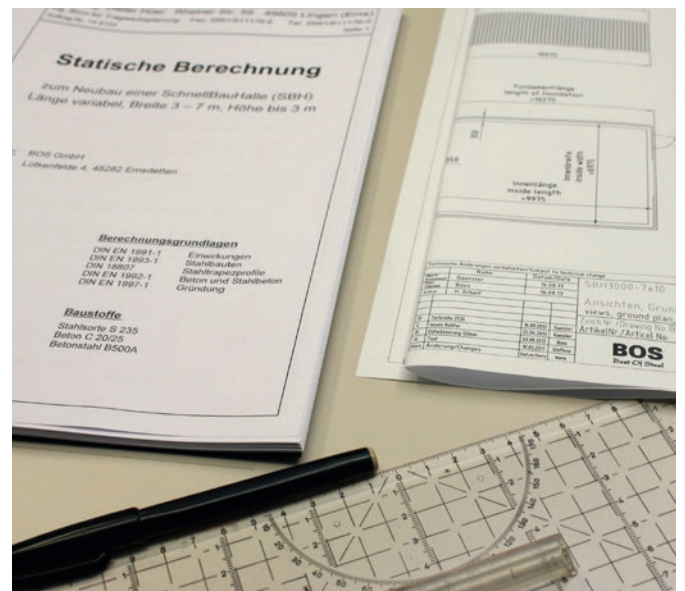

Planning permission and the necessary forms

You receive a verifiable structural analysis according to Eurocode 3 as well as view drawings with foundation plan.

OUR BESTSELLER



BEST OF STEEL

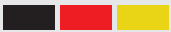

Made in Germany

Illustration: SBH3200-5x6

PERFORMANCE REQUIREMENTS:

You are looking for a **cost-effective and variable warehouse** with extra headroom, which can be built with or without foundation and modularly expanded later.

Quick-Build-Warehouse SBH2600 / SBH3200

THE SOLUTION:

- Can be extended in length at any time in modular 2m steps (Subject to technical change)
- Ground anchorage with ground nails
- Optional ground anchorage with dowels on foundation
- Verifiable structural analysis according to Eurocode 3 included
- Snow load safety of up to 320kg/m² depending on warehouse size
- Protective corner covers for additional safety
- Cost-effective self-assembly or, on request, full or supervised assembly service



ASSEMBLY IN JUST
A FEW HOURS
quick & easy



DIN EN 1090
REG.-NR. 0114502

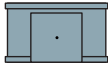
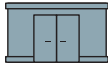

	<p style="text-align: center;">Door</p>  <p style="text-align: center;">Double door: 2 x 2.2m</p>				
SBH2600					
Width	(m)	4.1 <small>(Roller shutter and door measurements on request)</small>	5.1	6.1	7.1
Depth	(m)	4.1 to 30.1 <small>(can be extended in modular 2.0m steps)</small>			
Height	(m)	2.625			

	<p style="text-align: center;">Roller shutter & door</p>  <p style="text-align: center;">Roller shutter: 2.6 x 2.5m Door: in side wall, single door, 1.0 x 2.2m</p>		<p style="text-align: center;">Door</p>  <p style="text-align: center;">Door: double door, 2.3 x 2.4m or 2.6 x 2.7m</p>		
SBH3200					
Width	(m)	4.1 <small>(Roller shutter and door measurements on request)</small>	5.1	6.1	7.1
Depth	(m)	4.1 to 30.1 <small>(can be extended in modular 2.0m steps)</small>			
Height	(m)	3.225			



ACCESSORIES/OPTIONS: See page 44-45 for details.

- | | |
|-------------------------------------|---|
| 5 Burglar protection | 12 Electrical package |
| 6 Anti-theft security bar | 13 Light panel in the roof |
| 7 VdS approved security lock | 14 Sliding window |
| 8 Anti-condensation coating | 15 Additional side entrance door |
| 10 Exterior painting | |

FIELDS OF APPLICATION: See page 38-40 for details.

-  Building Sites
-  Housing
-  Storage Space
-  Self Storage
-  Tyre Storage

Fields of application

Containers and Warehouses



Building Sites

For safe storage of material and appliances on the building site. Highest stability for every day life in construction.



Building site container



Building site container



With 4 standard jack rings, up to 3 tons can be lifted by crane



Maintenance hangar

Fields of application

Containers and Warehouses



Housing – Can be used indoors and outdoors as well as being portable
Machines, materials and people are superbly protected from environmental influences.



Gas pump housing



Housing for an external control centre



Storage Space for industry, crafts and trade

Storage space at any time and any place- with highly flexible storage containers and warehouses from 2 to 200m².



Storage space for tyres: individually upgradable with commercially available shelving systems



Storage space for beverages

Fields of application

Containers and Warehouses



Self Storage

Our storage boxes and warehouses are ideally suitable for Self Storage- inside and outside. Extra rental space is created with very little effort.



Up to 3 Storage Boxes can be stacked on top of each other



Self Storage as additional rental space



Self Storage Space



Mobile use of the Storage Box – loading and unloading directly on the customer's doorstep



Storage Boxes in a former underground car park – central and easily accessible

Further information and more about the use of our containers can be found here: www.rr-solutions.se

References

Containers and Warehouses



Shelter at the Skatepark Emsdetten/Germany



SC3000 as storage space for a kite school



SC3000 as a sales booth



SC3000 as a motorbike garage



Container as storage space at an Open Air Festival



Container as a sales booth in Australia

References

Containers and Warehouses



SC3000 on a construction site



SC3000 as an equipment shed



SC3000 with wood panelling



ContainerCombination SCC2400 in a park as storage



SC3000 as housing for a power distribution box



SBH2600 in a garden as a tool and storage room

References

Containers and Warehouses



SC3000-4x2LZ as a tool shed

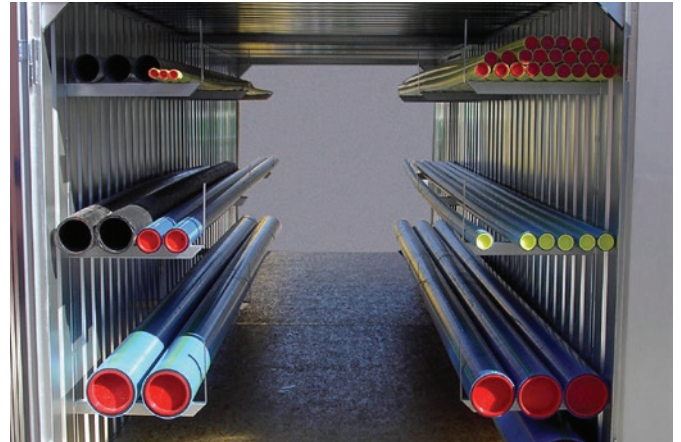

SCC2100-12x2 for pipe storage



SC3000-3x2SZ without flooring, level access e.g. with a forklift or pallet truck



SC3000-1x2SZ as a tool box in a garage



SC3000-1x2 can be relocated at any time



SC3000-6x2SZ as storage space

Accessories/Options

Containers and Warehouses

TIDINESS



Shelving system
 3 levels, 1/2/3m lengths, 420mm depth. From galvanized steel, load bearing capacity of 50kg per shelf bracket. Self-supporting construction so that the whole floor surface can be used. Adjustable in height in 100mm steps.
 Article no.: ZRS-3-1-420 (1m), ZRS-3-2-420 (2m), ZRS-3-3-420 (3m)



Tool rail
 Slot-in, galvanized tool rail for spades, shovels, brooms etc.

Article no.: ZGL-C



Clothes rail
 Slot-in, galvanized steel rail with 5 hooks for clothing, hats etc.

Article no.: ZKHL-C



Hose and cable suspension
 Slot-in, galvanized steel half shell for garden hoses, cables etc.

Artikel-Nr. ZSKA

SECURITY



Burglar protection
 Retrofittable security system including padlock for Containers/Quick-Build-Warehouses from 2010 onwards.

Article no.:
 ZEBS-1 (single door)
 ZEBS-2 (double door)



Anti-theft security bar
 Retrofittable security bar for single and double doors in solid steel with padlock.

Article no.: ZDSV-1-W (single door)
 Article no.: ZDSV-2-1750 (double door 1750mm)
 Article no.: ZDSV-2 (double door 1950mm)



VdS approved security lock
 Meets the special requirements of insurance companies.

For double doors.

Article no.: ZEBS-2VDS

Accessories/Options

Containers and Warehouses

SECURITY



8 Anti-condensation coating

The pre-applied coating on the underside of the roof absorbs humidity protecting stock effectively from condensation.

Article no.: ZAKW



9

Protective corner covers

Corner covers provide additional theft and collision protection as well as increased stability.

Article no.: ZSE-2100
(per piece)

COMFORT



10

Exterior painting

Finish with 2K layer thickness. Available in all RAL colours.

Article no.: ZAL



11

Access ramp

Suitable for single and double doors. Made of non-slip aluminium-duet-sheeting. 870x1460mm, load 250kg.

Article no.: ZAFR-920



12

Electrical package FutureBall

Can be hung on the wall or ceiling using mounted magnets. Foldable hooks for optional suspension. SMD-LED light, 5m connecting cable with earthing contact plug, plug socket, on/off switch.

Article no.: ZEP

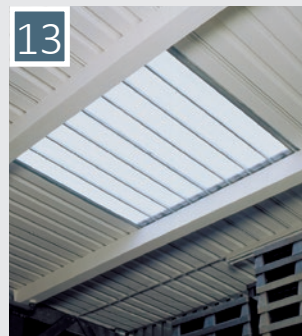

13

Light panel in the roof

A light panel in the roof provides light without using electricity (for containers 1x2m, for warehouses 2x2m).

Article no.: ZDLD-1x2
Article no.: ZDLD-2x2



14

Sliding window in high grade plastic

Sliding window (750 x 850mm) with single glazing and interior lock (as burglar protection) and shutters with magnetic catches (for securing when open).

Article no.: ZSFG



15

Additional side entrance door

Galvanized single steel door, 950x2200mm (WxHt).

Article no.: ZNET-1,0x2,2

Competence and know-how – that you can count on

Customers all over the world have relied on our experience and quality standards for more than 40 years. Quick-Build-Containers and Warehouses solve storage problems in the shortest time, are TÜV tested and guarantee a high level of work and operational safety. We focus on fast and simple assembly, high quality materials and a robust construction.

Proven Best-Point Technology – the material surface remains undamaged

In contrast to conventional production methods, the protective zinc coating is not damaged.

A 10 year anti-corrosion guarantee is given on the Best-Point Joints.

In our business field 'Steel Frames' we have been producing door frames in steel for more than 50 years – repeatedly awarded for outstanding design: www.rr-solutions.se



R&R Solutions AB
Kristinelundsgatan 4,
SE-411 37 Göteborg
Phone: +46 31 360 8283
E-Mail: info@rr-solutions.se

Web: www.rr-solutions.se



Quality



Environment



Safety



Energy

